

Model 1415

Description

Type	Safety relief valves	
Connections	ASME/ANSI B16.5	ANSI150 / 300 / 600 / 900 / 1500 / 2500
Material	Carbon steel A 216 WCB, A 217 WC6, S.S. A 351 CF3M, LCC, Duplex and SuperDuplex	
Temperature range	-196°C to +540°C	

Technical information

Applications	Steam, gases, vapours and liquids
Min. Set pressure	0,2 barg; With bellows 2 barg
Seat	metal-metal, PTFE, Viton and Stellite
Overpressure	10% for steam, gas and vapour 21% for fire exposure, 25% for liquids
Blowdown	10%
Tolerance Set pressure	± 3%

Requirements

Calculation	API RP 520
Design / Size	API STD 526, ASME Section VIII
Materials	EN / ASTM / ASME
Inspection	EN-4126-1/7 API 527 MSS-SP55
Tolerances	EN-4126-1 and ASME UG-126

Construction and materials

Item	Description	Material		
		Carbon steel	Stainless steel	DUPLEX
1	Nozzle	AISI-316L	AISI-316L	EN 1.4462
2	Body	A216 WCB	A351 CF3M	EN 1.4462
3	Bonnet	A216 WCB	A351 CF3M	EN 1.4462
4	Cap	A351 CF8	A351 CF8	EN 1.4462
5	Disc	AISI-316L	AISI-316L	EN 1.4462
6	Guide	AISI-316L	AISI-316L	EN 1.4462
7	Push Rod	AISI-316L	AISI-316L	EN 1.4462
8	Spring Button	AISI-303	AISI-303	EN 1.4462
9	Ajusting Screw	AISI-420	AISI-303	EN 1.4462
10	Lock Nut	AISI-303	AISI-303	EN 1.4462
11	Spring	1.8159 C. S.	AISI-302	Inconel X 750
12	Lever	A351 CF8	A351 CF8	A351 CF8
17	Release nut	AISI-304	AISI-304	AISI-304
18	Lever axis	AISI-303	AISI-303	AISI-303
19	Packing lever axis	AISI-303	AISI-303	AISI-303
20	Gasket cap	PTFE	PTFE	PTFE
21	Gasket bonnet	Graphite + S.S.	Graphite + S.S.	Graphite + S.S.
22	Gasket pack. lever	Viton	Viton	Viton
27	Bellows	AISI-316 TI	AISI-316 TI	AISI-316 TI
28	Soft seat	Viton / PTFE	Viton / PTFE	Viton / PTFE

Recommended spare parts

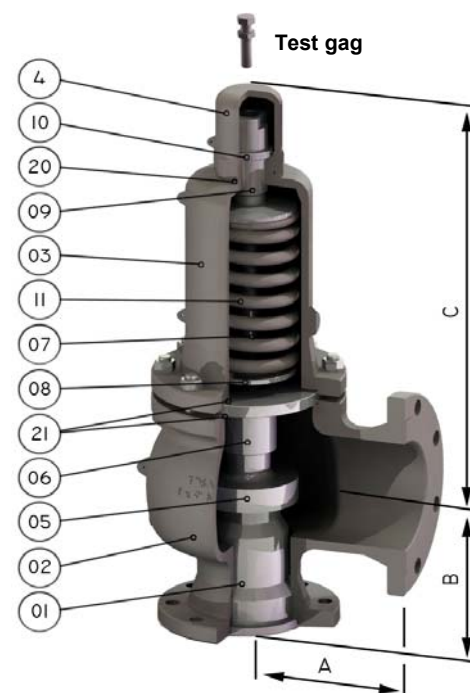

Options

Lifting device



Sealed packing lever



Open bonnet



Soft seat



Bellows



Model 1415

Dimensions

		Orif. (mm)	Area (mm ²)	ANSI 150				ANSI 300				ANSI 600			
				(mm)			Weight (kg)	(mm)			Weight (kg)	(mm)			Weight (kg)
D/E				A	B	C	W	A	B	C	W	A	B	C	W
D/E	1/2" D / E 1"	9,5/13	71/133	95	95	275	10	95	95	275	10	95	100	275	11
	3/4" D / E 1"	9,5/13	71/133	95	95	275	10	95	95	275	10	95	100	275	11
	1" D / E 1"	9,5/13	71/133	95	95	275	10	95	95	275	10	95	100	275	11
	1" D / E 2"	9,5/13	71/133	114	105	275	14	114	105	275	16	114	105	275	18
F	1 1/2" F 2"	16	201	121	124	315	17	121	124	315	17	152	124	315	20
	1 1/2" F 2" 300L	16	201	•	•	•	•	152	124	315	17	•	•	•	•
G	1 1/2" G 3"	21	346	121	124	400	26	121	124	400	26	152	124	400	28
	1 1/2" G 3" 300L	21	346	•	•	•	•	152	124	400	26	•	•	•	•
H	1 1/2" H 3"	26	531	124	130	400	26	124	130	400	26	•	•	•	•
	2" H 3"	26	531	•	•	•	•	124	130	400	27	162	154	400	32
J	2" J 3"	32,5	830	124	137	400	28	124	137	400	29	•	•	•	•
	3" J 4"	32,5	830	•	•	•	•	181	184	595	56	181	184	595	62
K	3" K 4"	40	1.195	162	156	595	56	162	156	595	56	181	184	595	62
L	3" L 4"	49	1.866	165	156	595	56	165	156	595	56	•	•	•	•
	4" L 6"	49	1.866	•	•	•	•	181	179	630	56	203	179	630	90
M	4" M 6"	55	2.376	184	178	630	88	184	178	630	90	203	178	630	110
N	4" N 6"	60	2.827	210	197	630	88	210	197	630	90	222	197	630	110
P	4" P 6"	73	4.185	229	181	630	88	229	181	630	90	254	225	630	120
	4" P 6" 300L	73	4.185	•	•	•	•	254	181	630	90	•	•	•	•
Q	6" Q 8"	96	7.238	241	240	690	140	241	240	690	140	241	240	690	190
R	6" R 8"	115	10.387	241	240	690	140	241	240	690	140	•	•	•	•
	6" R 10"	115	10.387	•	•	•	•	267	240	795	198	267	240	795	198
T	8" T 10"	147	16.972	279	276	800	210	279	276	800	220	•	•	•	•
V	10" V 14"	200	31.415	406	305	1.390	750	406	305	1.390	780	•	•	•	•
W	12" W 16"	228	40.828	406	359	1.432	800	406	359	1.432	850	•	•	•	•

		Orif. (mm)	Area (mm ²)	ANSI 900				ANSI 1500				ANSI 2500			
				(mm)			Weight (kg)	(mm)			Weight (kg)	(mm)			Weight (kg)
D/E				A	B	C	W	A	B	C	W	A	B	C	W
D/E	1 1/2" D 2"	9,5/13	71/133	140	105	315	19	140	105	315	24	•	•	•	•
	1 1/2" D 3"	9,5/13	71/133	•	•	•	•	•	•	•	•	178	140	325	30
F	1 1/2" F 3"	16	201	165	124	315	22	165	124	315	22	178	140	325	30
G	1 1/2" G 3"	21	346	165	124	430	28	•	•	•	•	•	•	•	•
	2" G 3"	21	346	•	•	•	•	175	156	444	41	175	156	444	50
H	2" H 3"	26	531	162	154	400	32	162	154	430	45	•	•	•	•
J	3" J 4"	32,5	830	181	184	595	70	181	184	595	65	•	•	•	•
K	3" K 6"	40	1.195	216	198	610	90	216	198	610	105	•	•	•	•
L	4" L 6"	49	1.866	222	197	820	140	222	197	820	120	•	•	•	•
M	4" M 6"	55	2.376	222	197	690	140	•	•	•	•	•	•	•	•
N	4" N 6"	60	2.827	222	197	820	140	•	•	•	•	•	•	•	•
P	4" P 6"	73	4.185	254	225	630	140	•	•	•	•	•	•	•	•