

# Model 1216 B Flanges

## Description

|                      |  |
|----------------------|--|
| Type                 | Safety and Relief valve  |
| Connections / Rating | PN,16, PN 40, ANSI150 and ANSI 300   |
| Material             | Stainless steel 316 L    Temperature range -30°C to +350°C    Cryogenic service until -196°C |

## Technical information

|                        |                                   |
|------------------------|-----------------------------------|
| Applications           | Steam, gases, vapours and liquids |
| Min. Set pressure      | 0,2 barg                          |
| Overpressure           | 10%                               |
| Blowdown               | Gases 10%, liquids 20%            |
| Tolerance Set pressure | ± 3%                              |

## Requirements

|             |  |
|-------------|--|
| Calculation | EN-4126-1 / 7                                      |
| Design      | EN-12516-1, EN-4126-1 / 7<br>DIN 259 and ANSI B2.1 |
| Materials   | EN   |
| Inspection  | EN-4126-1 / 7                                      |

## Construction and materials

| Item | Description        | Material     |               |
|------|--------------------|--------------|---------------|
|      |                    | Standard     | Cryogenic     |
| 1    | Nozzle             | AISI-316L    | AISI-316L     |
| 2    | Body               | A351 CF-3M   | A351 CF-3M    |
| 4    | Cap                | A351 CF-8    | A351 CF-8     |
| 5    | Disc               | AISI-316L    | AISI-316L     |
| 6    | Guide              | AISI-316L    | AISI-316L     |
| 7    | Push Rod           | AISI-316L    | AISI-316L     |
| 8    | Spring Button      | AISI-303     | AISI-303      |
| 9    | Ajusting Screw     | AISI-303     | AISI-303      |
| 10   | Tensor Nut         | AISI-303     | AISI-303      |
| 11   | Spring             | AISI-302     | INCONEL X 750 |
| 12   | Lever              | A351 CF-8    | A351 CF-8     |
| 17   | Release nut        | AISI-304     | AISI-304      |
| 18   | Lever axis         | AISI-303     | AISI-303      |
| 19   | Packing lever axis | AISI-303     | AISI-303      |
| 20   | Gasket cap         | PTFE         | PTFE          |
| 21   | Gasket             | PTFE         | PTFE          |
| 22   | Gasket pack. lever | Viton        | Viton         |
| 28   | Soft seat          | Viton / PTFE | Metal         |

   Recommended spare parts

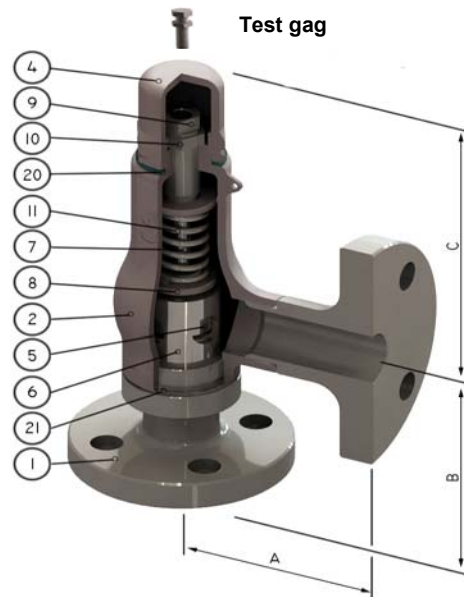

## Options

Lifting device



Sealed packing lever



Soft seat



## Dimensions

|           | Connections        |           | Orifice | Area<br>(mm <sup>2</sup> ) | A<br>(mm) | B<br>(mm) | C<br>(mm) | Weight<br>(kg) |
|-----------|--------------------|-----------|---------|----------------------------|-----------|-----------|-----------|----------------|
|           | Inlet              | Outlet    |         |                            |           |           |           |                |
| 1/2" x 1" | ANSI150 or ANSI300 | ANSI150   | 13      | 133                        | 70        | 90        | 155       | 3              |
| 3/4" x 1" | ANSI150 or ANSI300 | ANSI150   | 14      | 154                        | 70        | 90        | 155       | 3,2            |
| 1" x 1"   | ANSI150 or ANSI300 | ANSI150   | 16      | 201                        | 70        | 90        | 155       | 3,5            |
| 1/2" x 1" | ANSI150 or ANSI300 | BSP / NPT | 13      | 133                        | 45        | 90        | 155       | 3              |
| 3/4" x 1" | ANSI150 or ANSI300 | BSP / NPT | 14      | 154                        | 45        | 90        | 155       | 3,2            |
| 1" x 1"   | ANSI150 or ANSI300 | BSP / NPT | 16      | 201                        | 45        | 90        | 155       | 3,5            |
| 15 x 25   | PN 16 or PN 40     | PN 16     | 13      | 133                        | 70        | 90        | 155       | 3              |
| 20 x 25   | PN 16 or PN 40     | PN 16     | 14      | 154                        | 70        | 90        | 155       | 3,2            |
| 25 x 25   | PN 16 or PN 40     | PN 16     | 16      | 201                        | 70        | 90        | 155       | 3,5            |
| 15 x 1"   | PN 16 or PN 40     | BSP / NPT | 13      | 133                        | 45        | 90        | 155       | 3              |
| 20 x 1"   | PN 16 or PN 40     | BSP / NPT | 14      | 154                        | 45        | 90        | 155       | 3,2            |
| 25 x 1"   | PN 16 or PN 40     | BSP / NPT | 16      | 201                        | 45        | 90        | 155       | 3,5            |